

# Résonances cristallines

Climatic installation, interactive to the sun with sound.  
Scenocosme : Grégory Lasserre & Anaïs met den Ancxt

[www.scenocosme.com](http://www.scenocosme.com)

Scenocosme : Grégory Lasserre / Anaïs met den Ancxt  
scenocosme@gmail.com - Tel : +33 6 61 09 50 52





**Le parcours des Fées - Parcours artistique dans les Hautes-Alpes - Vallée de Crévoux (Fr)**



## Description of the artwork

«Résonances cristallines» is a sonorous artwork composed of crystalline shapes suspended in a tree. Each crystal resonates according to the rays of the sun light. Along the branches, each element produces different notes depending on the intensity and orientation of the sun. This work is sensitive to the evolution of the weather and generates sound variations during the day.

Like a singular metallophone, the crystals contain resonators inside. The electronic creates the vibration and the solar devices are autonomous. Each one has the ability to emit a vibratory note when the sunlight illuminates them. Each crystal is illuminated differently throughout the day.

According to the position of the sun and the weather, the sunlight illuminates and activates the resonators. The singular chimes of «Résonances cristallines» are also punctuated by instant of silence at the passage of clouds.

**More informations and video:** [www.scenocosme.com/resonances\\_cristallines\\_e.htm](http://www.scenocosme.com/resonances_cristallines_e.htm)





Art & Nature - parcours d'art contemporain / Site des Renaudières - Carquefou (Fr)

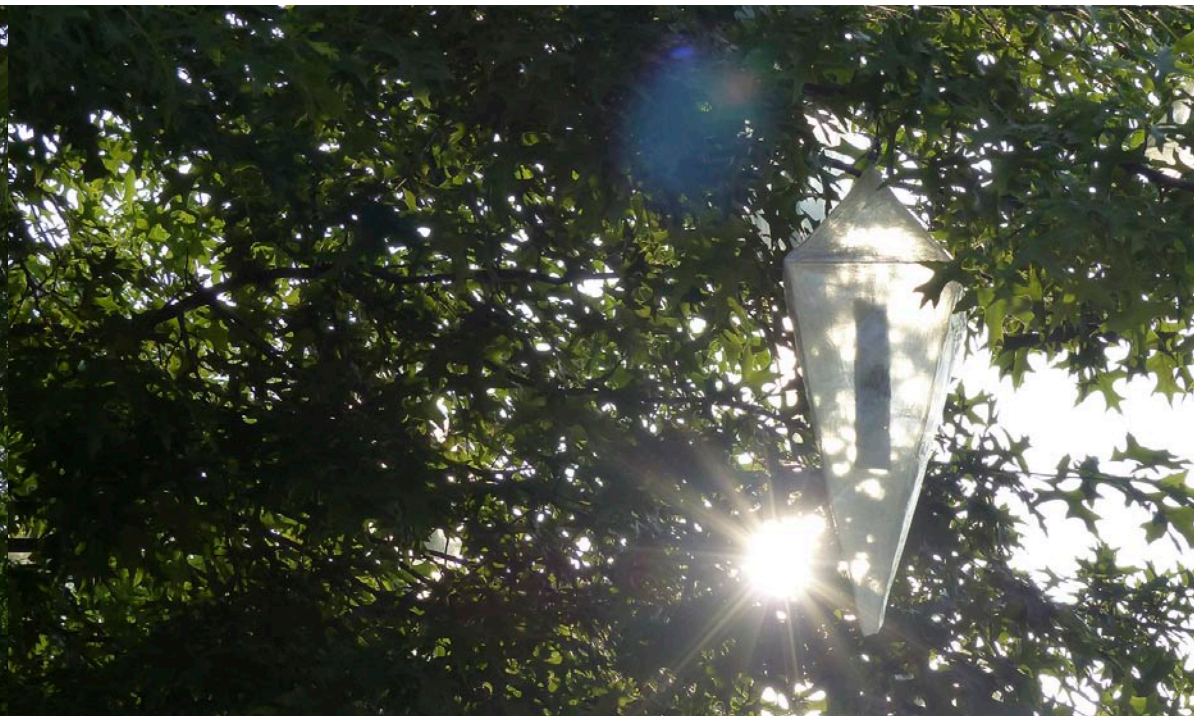



Esplanade du Musée d'Art Contemporain de Montélimar (Fr)

## **Technical specification**

The installation is made with several translucent crystal-shaped structures of different sizes. Each crystal contains a rectangular metal element. Each interactive device is secured and protected inside.

On each piece of metal, there is a small autonomous electronic and a solar device which is used as a resonator. It is made of a small solar panel and a tiny motor. When the sun illuminates the translucent crystal, it activates the micro-motor.

Each crystal has the ability to resonate by emitting a different tone.

The level of the sound changes according to the intensity of the sun. The installation is delicate in low cloudy weather and becomes more present by clear blue skies.

The translucent crystals are composed of flexible PVC and tape.

## **The sound creation**

The intimate and organic sounds can evolve slowly with the intensity of the sun. The score played is not written in advance but depends only of the intensity of the sun over the days : the weather and the seasons.

The installation is like a metallophone composed of metal bars of different sizes and tones. Each crystal emits a light tone.

A sign, drawn or suggested will invite the spectators to go and take the time to listen to the work at different times of the day.

## **Installation of the artwork**

We need a beautiful tree to arrange the several interactive crystals on the branches. Each crystal is very light and can be easily suspended on the branches.



Details of the interior of one sound device

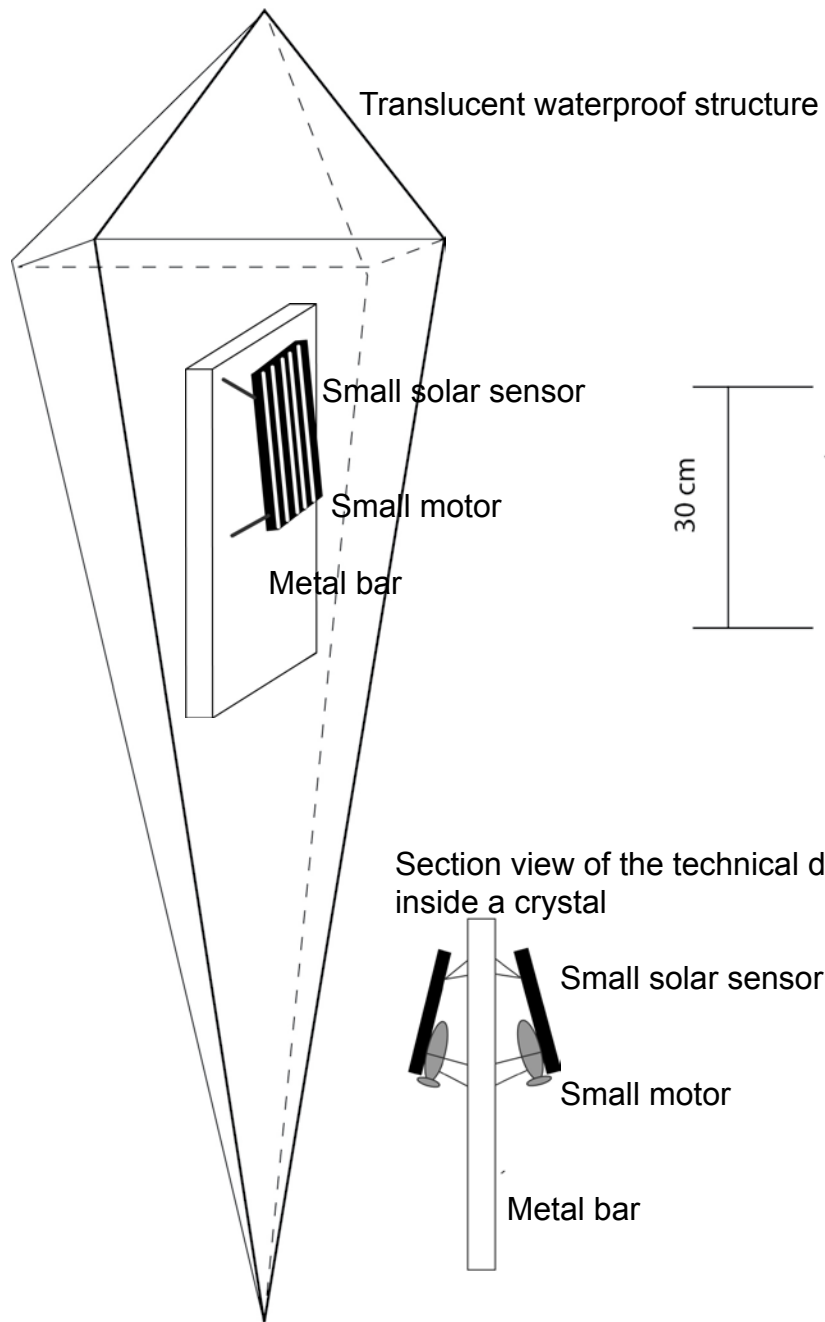
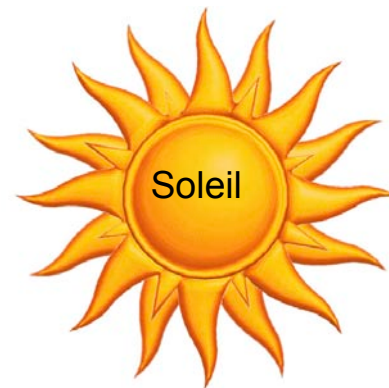

Possible dimensions of the different crystals

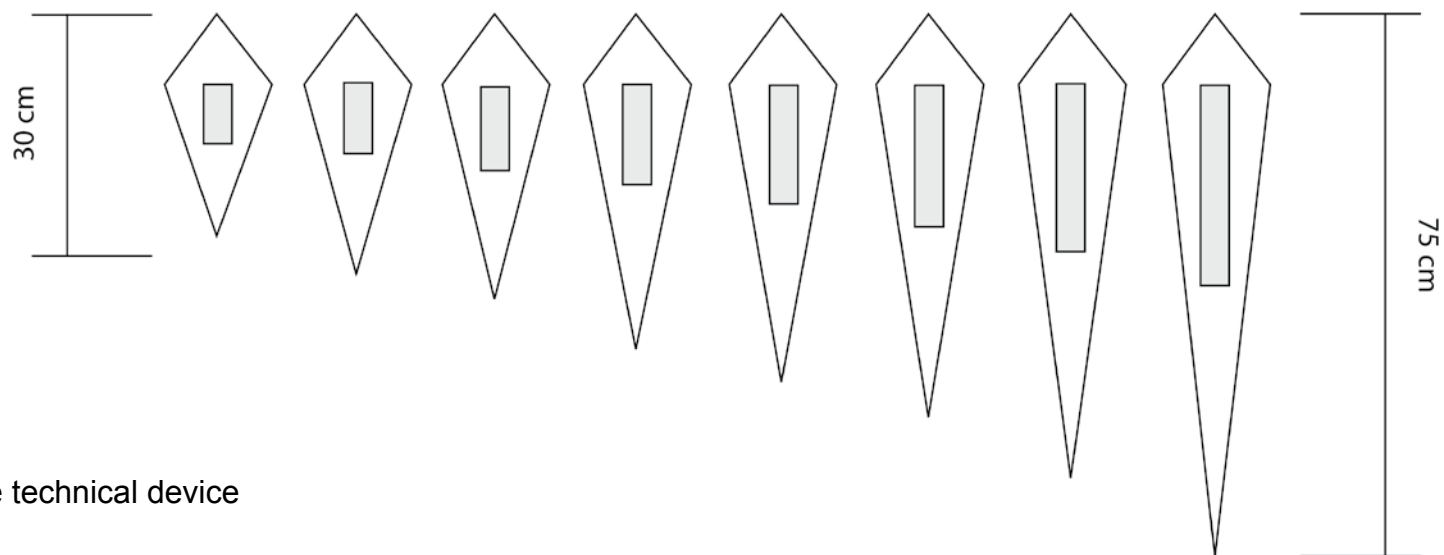

Section view of the technical device inside a crystal

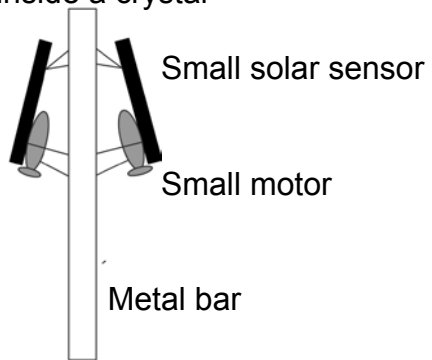





Test dans notre jardin



## **Artistic process hybridizations between nature and digital technology**

As media artists, Scenocosme: Grégory Lasserre & Anaïs met den Ancxt, explore capacities of technologies in order to draw sensitive relationships through specific stagings where senses are augmented. Their works came from possible hybridizations between the living world and technology which meeting points incite them to invent sensitive and poetic languages.

Thus, through a poetic interpretation of invisible mechanisms, technologies allow them to draw sensory relationships, and to generate unpredictable living interactions. Their hybrid artworks play with their own augmented senses. They live with technology and have reactions which escape deliberately to their control. When they create interactive works, Scenocosme invent sonorous or/and visual languages. They translate the exchanges between living beings and between the body and its environment. They suggest interrelations where invisible becomes perceptible. Materialized, our sensations are augmented.

They also explore invisible relationships with our environment: they can feel energetic variations of living beings. They design interactive artworks, in which spectators share extraordinary sensory experiences.

### **Other sound installations :**

Pulsations : [www.scenocosme.com/pulsations\\_e.htm](http://www.scenocosme.com/pulsations_e.htm)

Hylé-Hélios : [www.scenocosme.com/hyle\\_helios\\_e.htm](http://www.scenocosme.com/hyle_helios_e.htm)

Matières sensibles : [www.scenocosme.com/matiere\\_e.htm](http://www.scenocosme.com/matiere_e.htm)

Echos: [www.scenocosme.com/echos\\_e.htm](http://www.scenocosme.com/echos_e.htm)

Ecorces : [www.scenocosme.com/ecorce\\_e.htm](http://www.scenocosme.com/ecorce_e.htm)

Kymapetra : [www.scenocosme.com/kimapetra\\_en.htm](http://www.scenocosme.com/kimapetra_en.htm)

Akousmaflore: [www.scenocosme.com/akousmaflore\\_en.htm](http://www.scenocosme.com/akousmaflore_en.htm)

Phonofolium: [www.scenocosme.com/phonofolium\\_e.htm](http://www.scenocosme.com/phonofolium_e.htm)

## Scenocosme : Grégory Lasserre & Anaïs met den Ancxt : [www.scenocosme.com](http://www.scenocosme.com)

The couple artists Gregory Lasserre and Anais met den Ancxt work under the name Scenocosme. They live in the Rhone-Alpes region in France. Their singular artworks use diverse expressions: interactive installations, visual art, digital art, sound art, collective performances etc.... Scenocosme mix art and digital technology to find substances of dreams, poetry, sensitivity and delicacy. These artists overturn various technologies in order to create contemporary artworks. Their works came from possible hybridizations between the technology and living world (plants, stones, water, wood, humans...) which meeting points incite them to invent sensitive and poetic languages. The most of their interactive artworks feel several various relationships between the body and the environment. They can feel energetic variations of living beings and design interactive stagings in which spectators share extraordinary sensory experiences. Their artworks are exhibited in numerous museums, contemporary art centres and digital art festivals in the world.

They have exhibited their interactive installation artworks at ZKM Karlsruhe Centre for Art and Media (Germany), at Daejeon Museum of Art (Korea), at Museum Art Gallery of Nova Scotia (Canada), at National Centre for Contemporary Arts (Moscow), at Contemporary Art Museum Raleigh (USA), at Bòlit Centre d'Art Contemporani (Girona) and in many international biennals and festivals : Art Center Nabi / INDAF (Seoul), BIACS3 / Biennial International of Contemporary Art of Seville (Spain), Biennial Experimenta (Australia), NAMOC / National Art Museum of China / TransLife / Triennial of Media Art (Beijing), C.O.D.E (Canada), Futuresonic (UK), WRO (Pologne), FAD (Brasil), ISEA / International Symposium on Electronic Art (2009 Belfast, 2011 Istanbul, 2012 Albuquerque, 2013 Sydney), EXIT, VIA, Lille3000, Ososphere, Scopitone, Seconde nature (France)... during important events : World Expo (Shanghai), Nuits Blanches (Toronto, Halifax, Bruxelles, Brighton, Amiens, Segovia, Bucharest), Fête des lumières (Lyon)... and in various art centers : MONA (Australia), MUDAC, Fondation Claude Verdan (Lausanne), Musée lanchelevici (Belgium), Kibla (Slovenia), Banff Centre (Canada), Villa Romana (Firenze), Utsikten Kunstsenter (Norway), Watermans (UK), Centre des arts d'Enghien-les-Bains, Gaîté Lyrique (Paris) etc.

Full biography : [www.scenocosme.com/PDF/scenocosme\\_BOOK\\_EN.pdf](http://www.scenocosme.com/PDF/scenocosme_BOOK_EN.pdf)

Wikipedia : <https://en.wikipedia.org/wiki/scenocosme>

### Previous exhibition of Résonances cristallines (Creation 2018)

- Esplanade du Musée d'Art Contemporain de Montélimar (Fr)
- Jardin du Musée des Beaux-Arts et d'Archéologie Joseph-Déchelette - Roanne (Fr)
- Art & Nature - parcours d'art contemporain / Site des Renaudières - Carquefou (Fr)
- Le parcours des Fées - Parcours artistique dans les Hautes-Alpes - Vallée de Crévoux (Fr)
- Pavillon Duhamel / Square Brioussel-Bourgeois - Mantes-la-Jolie (Fr)

